

Fumis AIR

AUTOMATIC REGULATION OF COMBUSTION PROCESS FOR WOOD STOVES AND FIREPLACES

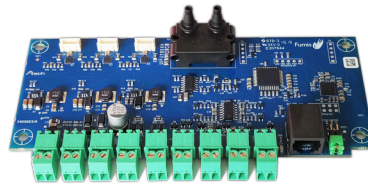

Circuit board dimensions:
150 x 80 x 30 mm



Fumis AIR
smartphone app

KEY BENEFITS

- Increased efficiency and lower emissions
- Fully customizable and modular: mechanical parts, electronic parts, combustion phases, power levels, and types of user interface
- Increased safety and comfort of the user
- Patented technology
- Low development costs for the manufacturing of heating appliances
- Rapid time to market
- Requires minor design changes in your stove

ABOUT FUMIS AIR

Fumis AIR is a system that automates combustion process in the wood stoves and fireplaces. It allows the manufacturer of wood stoves and fireplaces to develop highly efficient stoves that are controlled either with smartphone application or by buttons on the stove (optional). Since Fumis AIR is in its essence a PLATFORM, it is designed to

be modular and customized for the manufacturer's needs. Combustion process and all other features are specified by the manufacturer of the stoves. Since the end product – the automatic wood stove – includes the manufacturer's know-how, it makes the product unique.

HOW DOES FUMIS AIR FUNCTION

It is installed on the air inlet and it regulates primary, secondary (optional), and tertiary (optional) air. It is a highly advanced system that monitors the temperature of the flue gases, draft (optional) and the oxygen (optional) content in flue gases. It includes a Bluetooth receiver for a smartphone application. The electronic circuit also includes additional input for i.e. ambient temperature sensor, and additional output for i.e. an ambient fan. There is also a possibility to include a battery for safety reasons in case of black-outs of the mains power. The sensors regulate

the three stepper motors that manipulate the air streams. There are a myriad of other options, which can be seen in the section Technical characteristics.

The air streams are regulated according to the parameters, which are defined by the manufacturer. We only provide the program with guideline for best performance, best practices and we offer complete technical support to help you along the way.

TEST RESULTS

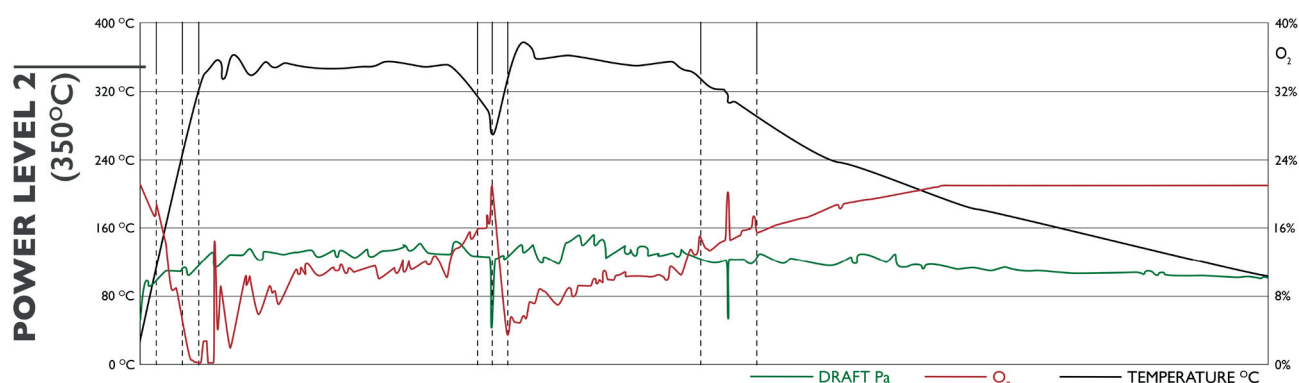

This graph shows how Fumis AIR regulates the combustion process. The power level was set to 350°C, which was achieved by controlling of the primary, secondary and tertiary

air. The dampers opened/ closed depending on the flue gas temperature, draft and oxygen content. Thus, it is possible to achieve higher efficiency and lower emissions.

OPTIONAL EQUIPMENT



Actuators



Lambda probe



Linear stepper

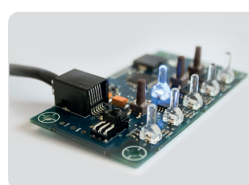

Interfaces

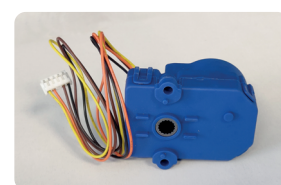

Rotary stepper

TECHNICAL CHARACTERISTICS

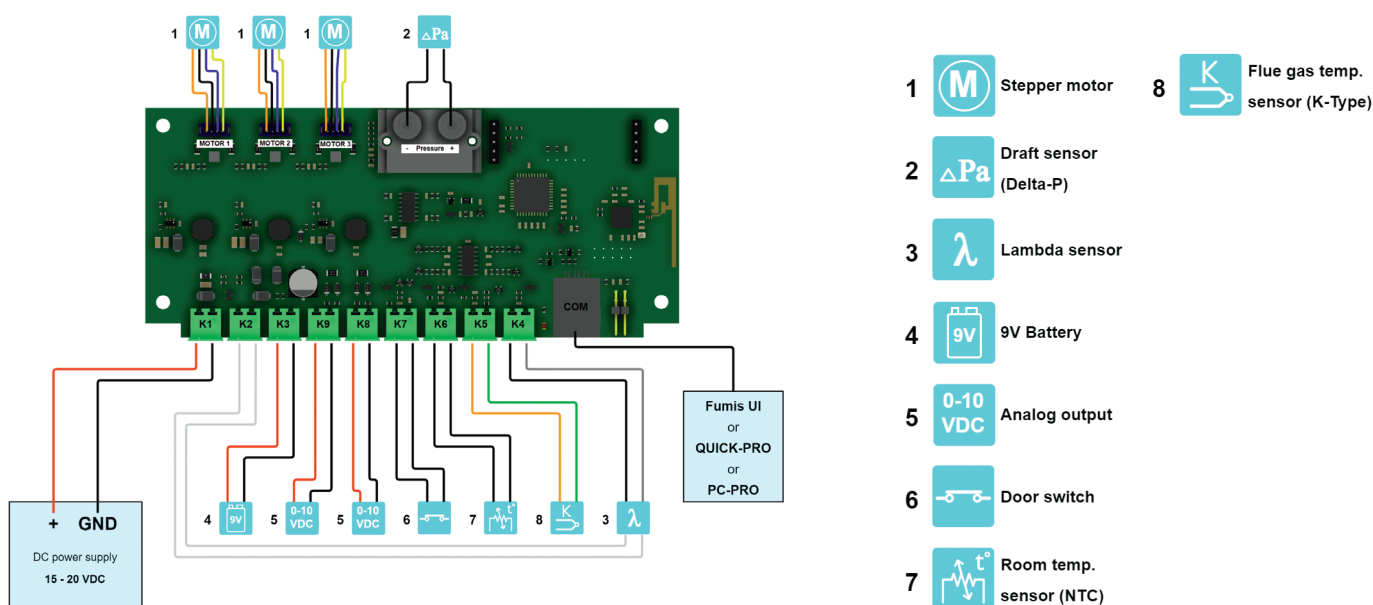

DISCLAIMER: "Information contained in this publication regarding device applications and the like is provided only for your convenience and may be superseded by updates. It is your responsibility to ensure that your application meets with your specifications. ATech makes no representation or warranties of any kind whether express or implied, written or oral, statutory or otherwise, related to the information, including but not limited to its condition, quality, performance, merchantability or fitness for purpose. ATech disclaims all liability arising from this information and its use. No licenses are conveyed, implicitly or otherwise, under any ATech intellectual property rights."